

Vibration Energy Harvesting VEH-APA 400M-MD

Objective

In many dynamic structure, a part of the produced mechanical vibration energy is unused and simply lost. For such structures, where need of electrical energy may be critical, a system which is able to transform the mechanical energy in a scavenged electrical energy is very interesting. Thanks to their high energy density and electro-elastic coupling, amplified piezoelectric actuators from CEDRAT TECHNOLOGIES are deemed candidate to harvest efficiently mechanical vibrations. This vibration energy harvesting system (VEH) developed by CEDRAT TECHNOLOGIES allows:

- Wireless and self powered integrated devices (sensors) avoiding expensive and time consuming hardwiring on mechanical structures,
- Removal of the battery and extension of the lifetime indefinitely,
- Robustness in severe industrial environment.

Description

The vibration energy harvesting system from CEDRAT TECHNOLOGIES is composed of 2 parts described here below.

- **An APA 400M-MD based proof mass** (fig. 1): It is a standard APA 400M which is mechanically damped (MD) via an elastomer part and set up in proof mass configuration. The APA 400M (fig 2) is composed of a piezoelectric ceramic preloaded along the main axis of an elastic and elliptic shell, acting as a mechanical amplifier along the short axis. The proof mass configuration consist of an additive counter mass affixed on one APA 400M-MD interface. The role of this counter mass is firstly to magnify the displacement of the APA 400M-MD with less input energy and secondly to tune the resonance frequency of the harvesting system at the frequency range of the vibrating structure. The mechanical vibrations injected to the base interface of APA 400M-MD proof mass are converted into AC electrical energy and transferred to the load via electrical wires and an electronic converter.
- **An AC-DC & DC-DC electronic converter** (fig.3): The role of this electronic converter is to deliver and to fit the output electrical energy from the proof mass to the load. Most of loads need DC Power, so the first step is to convert the AC signal into DC signal thanks to a first AC-DC converter stage. To optimize the electrical power transmission from the proof mass to the load, it is important to match the 2 impedances.

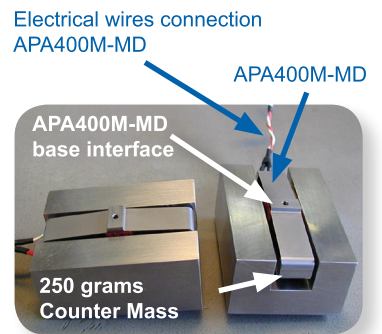

Figure 1: APA 400M-MD based proof mass.

Figure 2: APA 400M
Displacement=400 μ m ; Blocked Force=38N ; Stiffness=0.1 N/ μ m ; Blocked-Free resonance frequency=495 Hz.

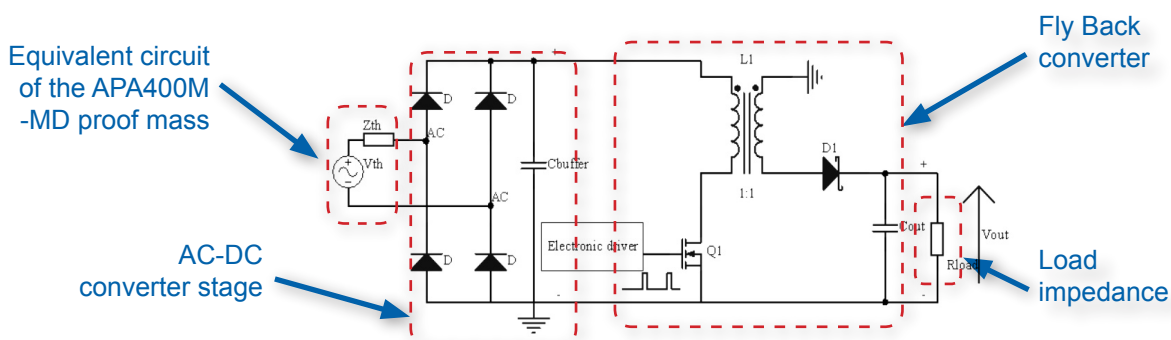
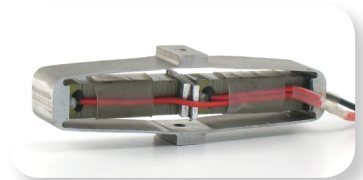
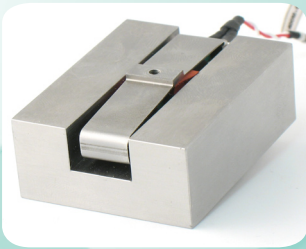

Figure 3: Schematic view of the AC-DC & DC-DC electronic



Vibration Energy Harvesting VEH-APA 400M-MD

That is why we add a second stage DC-DC converter (Fly Back converter) which allows a quasi constant power flow from the proof mass to the load whatever its impedance value (fig 4). The harvesting efficiency of the VEH system is defined as the ratio of the harvested electrical power over the input mechanical power.

Performance of the APA 400M-MD based VEH system

References	Unit	APA400M-MD based VEH System
<i>Notes</i>		
<i>Technological baseline</i>		APA400M-MD
Harvested vibration frequency	Hz	110
Harvested vibration amplitude	$\mu\text{m p-p}$	45
Max Harvesting efficiency (with Fly Back converter)	%	48% (36%)
Max Harvested Power	mW	95
Dimensions of the proof mass	mm^3	50 x 32 x 22
Weight of the proof mass	grams	270
Mechanical interface		2 flat surfaces 5*10 mm2 with M2.5 threaded hole
Electrical interface		TBD

Remarks

- An APA 400M-MD based VEH system has a greater efficiency than piezo patches.
- Specific APA® based VEH system can be developed depending on customer's specifications.
- For high amplitude vibrations at low frequency, CEDRAT TECHNOLOGIES can also develop magnetic actuator based VEH system.

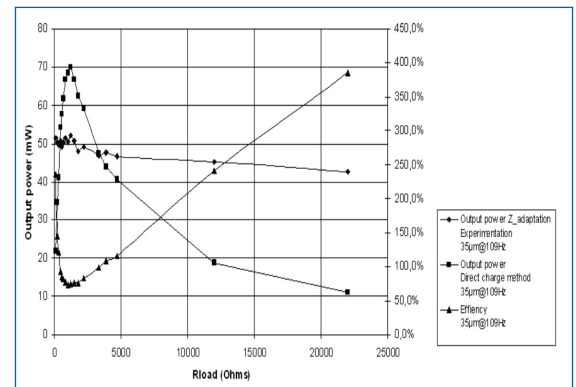

Figure 4: Output power & efficiency of the APA 400M-MD with Flyback circuit & comparison with direct charge method (ie without Flyback).

For more information, please contact:

CEDRAT TECHNOLOGIES
15 Chemin de Malacher - Inovalée
38246 Meylan Cedex - France
actuator@cedrat.com
Phone: +33 (0)4 76 90 50 45 - Fax: +33 (0)4 56 38 08 30