

Tunable Proof Mass Actuator Based on a Pendulum Structure

Frank Claeysen⁽¹⁾, François Barillot⁽¹⁾, N.Lhermet⁽¹⁾, Chris May⁽²⁾, Ciro Natale⁽³⁾, Alexandre Pages⁽¹⁾
¹Cedrat Technologies, Meylan, France ; ²LPA-ZIP, Saarbrücken, Germany ; ³DII-Sun, Naples, Italy

Abstract:

Proof mass dampers are currently used in aircraft structures, but are not active, which introduce performance limitations. Proof Mass Actuators based on spring-mass structures are an interesting technique for active vibration control, but it is difficult to design them for operation below 100 Hz, especially if high dynamic forces are required. The proof of concept of a Tunable Proof Mass Actuator (TPMA) based on a pendulum structure has been assessed into the Mesema FP6 EC project targeting an Helicopter application. This pendulum structure allows achieving a very low resonant frequency (4 to 20Hz) associated with large inertial forces (>1kN) due to large vibration amplitude (10mm). To obtain a tunable resonant frequency, an internal actuator modifies the TPMA pre-load force. Two types of internal pre-load actuators are compared: An Amplified Magnetostrictive Actuator (AMA) and an Amplified Piezoelectric Actuator (APA). In both cases, the tunability has been observed, each type offering different advantages. This novel concept opens a new field of possibilities for making very low frequency semi active dampers or dynamic vibration absorbers for aircraft, helicopters and civil engineering.

Keywords: Magnetostrictive, Piezoelectric, Actuator, semi active dampers, dynamic vibration absorber,

Introduction

Passive proof mass dampers, based on elastomeric mounts are currently used for the reduction of vibrations in flexible structures, such as for example the frame of the ATR72 civil aircraft by [1].

A proof-mass damper is basically a dissipating spring connected on one end to the structure and to the other end to a free reaction mass. The reaction mass generates dynamic inertial forces due to its linear acceleration at and above resonance. On its other end, the proof mass damper is fixed to the flexible structure to be dampened. When the resonant frequency of the proof mass damper is tuned with the vibration mode of the flexible structure, such a structural mode is broken and the associated vibration level is significantly reduced (Fig 1). Such proof-mass dampers are also called Dynamic Vibration Absorbers (DVAs).

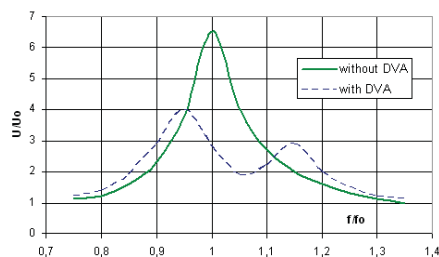

Fig.1: Effect on the frequency response of a structure due to a DVA tuned with the resonance

However effectiveness of passive proof mass dampers depends strongly on how precisely they are tuned. In many applications, the tuning frequency is

not quite constant and varies with the operating conditions of the system. For example in an helicopter, a typical applications for DVAs [2,3], the rotor frequency varies with the flight conditions, which changes slightly the structural modes. For this, electric tunability would be welcome. Another limitation of usual proof-mass dampers is their incapability to address both very low frequency operations (10-30Hz) and large force generation (>1kN), as needed in helicopter or civil engineering applications.

To address these issues, a new low frequency Tunable Proof Mass Actuator (TPMA) has been developed within the MESEMA EU project [4].

In contrast to usual spring-mass proof mass dampers, the TPMA is a pendulum structure. Pendulum structures have already been referred for DVAs [5]: A pendulum allows achieving a very low resonant frequency associated with large inertial forces. Governing parameters are the moving mass and a returning force.

The proposed TPMA is a large-scale pendulum using either Amplified Magnetostrictive Actuators or Amplified Piezo-electric Actuators for performing the tunability function. Several small scale models of magnetostrictive DVAs have been developed in MESA or MESEMA EC projects [6] and have been a starting point for the design of the TPMA.

The paper presents at first the Amplified Magnetostrictive Actuators concept, because it is a key component for the TPMA. Secondly, it presents the design and the performances of the TPMA.

Amplified Magnetostrictive Actuators AMA

The amplified magnetostrictive actuators (AMAs) developed by Cedrat are based on a Magnetostrictive rod and on a shell which performs both the prestress of the magnetostrictive rod and the amplification of displacement. It is a concept patented by Cedrat Technologies and mostly used for manufacturing its Amplified Piezoelectric Actuators APAs [7,8].

A typical AMA structure is presented on figure 2 and 3, related to an AMA biased with Permanent Magnets. The long active axis is a stack of permanent magnets in series with 7 short rods of Terfenol-D 8mm in length, 8mm in diameter. It is prestressed at about 30MPa and biased at about 100kA/m.



Fig.2: Mounted PM biased AMA400ML



Fig.3: Dismounted PM biased AMA400L

When the stack of magnetostrictive rods is driven by a magnetic field provided by the coil, the stack expands or contracts (depending on the direction of the coil field vs the PM field) along to the long axis. Then the shell contracts or expands on the short axis producing an amplified displacement. In static condition, the amplification of displacement (shell short axis / long axis) is a factor 2.2. In dynamic at resonance, the factor is 3.3. This is a bit different than the static factor because of slightly different mode shapes.

Because of all these effects and the stack structure, this actuator cannot easily be analysed without a 3D electromechanical model. The fig. 4 presents the low frequency deformation of the actuator computed with the ATILA FEM accounting for the 3D piezo-magnetic coupling (biased magnetostriction), the 3D structure and the current excitation into the coil.

According to ATILA, 1 Ampere in the coil produces a 16kA/m H field and in quasi static condition, this field generates a 11.0 μm peak displacement.

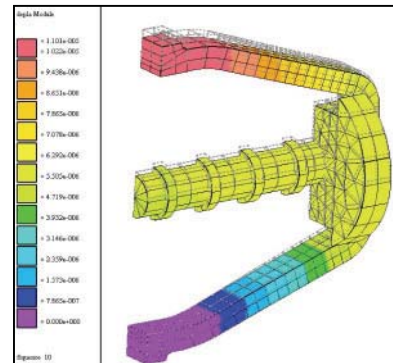

Fig. 4 : ATILA modelling of the AMA400L

The response curve of displacement par ampere, measured at excitation low level, gives a displacement per ampere of 10.5 $\mu\text{m}/\text{A}$, which confirms the computation result, and shows a resonance at 3.1kHz with a Q factor of 20.

With these values, ATILA shows that at resonance, the maximum current is 1.45A_{peak} and the maximum H field is 23 kA/m, because with these values the dynamic stresses amplitude in the rod meet the prestress value. This leads to a theoretical peak-to-peak displacement equal to 640 μm .

Measurements at resonance with this current gave a large peak-to-peak displacement equal to 505 μm . The difference is explained by the non linearities occurring at high level. Indeed the Q factor at high level was found about 16, which is lower than the one measured at low level. From this displacement and the amplification factor calculated with ATILA, the Terfenol-D deformation is found equal to about 2730ppm peak-to-peak.

This example shows how the analysis of the stroke limits of a complex AMA is performed.

A similar approach was applied for the AMA230L (fig 5) used in the TPMA. The difference of the selected AMA is in the use of a DC-current bias. This choice is lead by the need for a stiffer shell and by the interest for comparison and interchangeably with the APA230L Amplified Piezo Actuator [8]. In both cases, the metallic shell is the same so the actuator volume is similar. The AMA230L Terfenol-D rod is 100mm long and 10mm in diameter. It is prestressed at 30MPa. The coil is 1445 turns. The performance is given in table 1. The AMA offers a smaller static stroke needing less voltage, as in [9], but offer larger resonant stroke than in static [10].



Fig.5: AMA230L preloading actuator for TPMA

	AMA230L	APA230L
DC Stroke	180µm	230µm
DC Force	700N	1350N
Voltage for DC stroke	36V	150 V
Current for DC stroke	6A	< 1mA
Coupling factor @fr	48% @Io=3A	53% @Io=3A
Resonant frequency	2,7kHz @Io=3A	3,1kHz @Io=3A
Max stroke at resonance	280µm	230µm

Tab.1: AMA230L and APA230L performances

TPMA Structure & Performances

Based on an initial concept (fig 6) from LPA-ZIP [6], a new large TPMA prototype was designed, manufactured and tested by Cedrat Technologies. It is based on a pendulum principle: A usual pendulum makes use of gravity to generate the returning force and to define the natural resonant frequency.

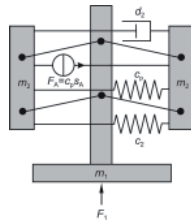

Fig.6: TPMA initial concept

The realised TPMA is shown in fig.7&8. The moving mass is 6.7kg, while the total mass is 12.2kg. The blades are 300mm long. The returning force combines a mechanically adjustable pre-load performed by a spring mechanism and an electrically adjustable pre-load performed by an internal preloading actuator. Both types of pre-loading actuators AMA230L and APA230L have been tested: They are good candidates for this application since they are small, compact and produce high forces with low power consumption. As a consequence, the pendulum resonant frequency can be adjusted mechanically (by easy manual screwing operation) and electrically (by the actuator).

The targeted low resonant frequencies have been achieved experimentally (fig 9). The mechanical tunability given by the relationship between the pre-load and the resonant frequency has been measured with manual mechanical setting of the pre-load.

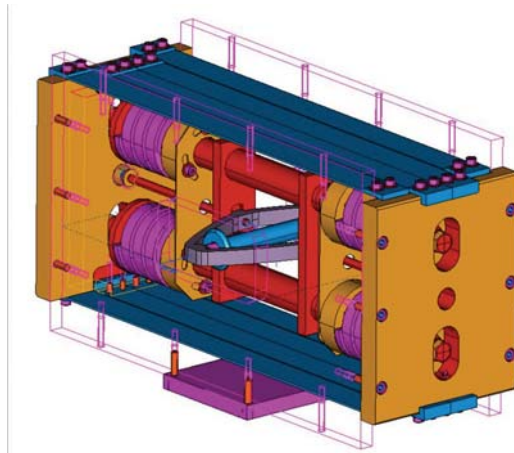

Fig.7: TPMA CAD view

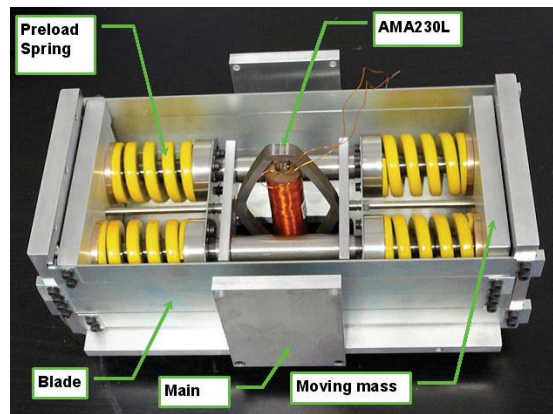

Fig.8: TPMA prototype

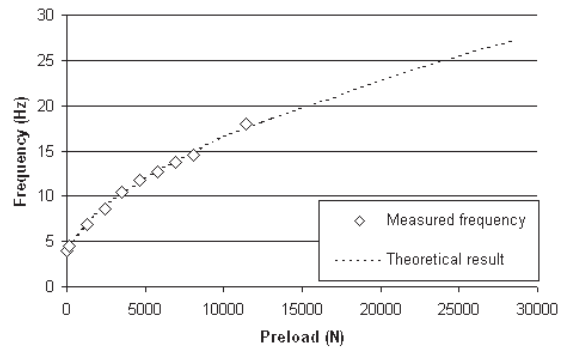

Fig.9: Measured & theoretical freq. vs Preload

It is closed to theoretical frequency based on the following model:

$$F = n.F_0 + \Delta F$$

$$f = \frac{1}{2\pi} \sqrt{\frac{F}{M.L} + \frac{K}{M}}$$

Where:

- ΔF : Force offset (least square) = 150 N
- F_0 : Spring force factor (least square) = 2259N/ turn
- L : blade length = 0.3m
- K : ½ blade stiffness (static measure) = 2100 N/m
- M : ½ Mass (static measure) = 3.32 kg

ΔF and F_0 are computed using a least square method so as to match the experimental results.

The electrical tunability has been established experimentally with both pre-loading actuators. For example in fig.9, TPMA resonant frequency is set to 11.2Hz, which corresponds to a pre-load of 4.3kN according to fig.8. Applying 150V to the APA, increases the frequency to 12.0Hz, corresponding to a pre-load of 5kN. Max variations of pre-load are about 700N with the APA (from 0V to 150V) and 500N with the AMA (from 0A to 4A due to thermal limitation). At 1kN pre-load, the TPMA resonant frequency shifted from 6.4Hz to 7.7Hz, representing an absolute shift of $\Delta F=1.26\text{Hz}$ and a relative shift of 20%. The absolute and relative shifts decrease with higher pre-loads. Similar results have been obtained on a vibration pot by DII-Sun (fig.10).

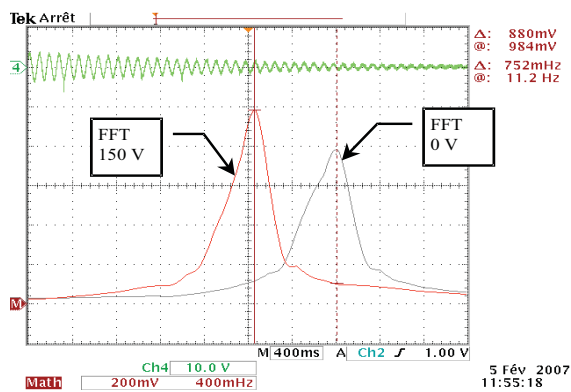

Fig.10: Frequency response of TPMA vibration speed with preload actuator on (150V) or off (0V)

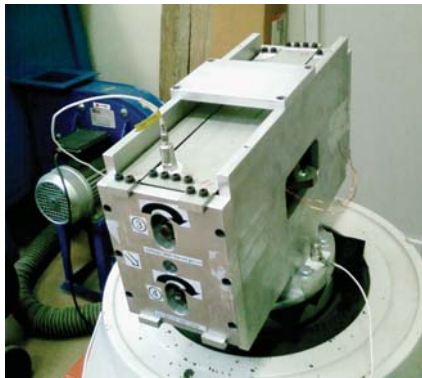

Fig.11: TPMA in vibration test set-up

Due to its design, the TPMA can accept amplitudes of vibration of the moving mass as large as $u=10\text{mm}$. This displacement capability was tested and exploited in most of the experiments. The corresponding acceleration is given by: $\gamma = \omega^2 u$. The inertial force produced by this motion is determined by: $F = m \cdot \gamma$ where is the moving mass ($m = 6.7\text{kg}$).

With a 10mm vibration, the produced dynamic inertial force achieves up to 1.5kN at 25Hz.

Conclusion

The Tunable Proof Mass Actuator prototype based on AMA or APA provides several proofs of concept: The resonant frequency can vary from 4 to 20Hz. The motion of the moving mass can achieve amplitude up to 10mm. The dynamic inertial force produced by the TPMA can achieve up to 1.5kN. The mechanical tunability is observed over a very large frequency range versus pre-load. The electrical tunability is observed by a frequency shift of the resonance versus applied voltage. The requirement for the electric tunability can be lower than 1W with APA and less than 36V with AMA.

Acknowledgement

This work was performed within the context of the EU MESEMA project, funded under the 6th Framework Programme of the European Community (Contract N. AST3-CT-2003-502915).

References

- [1] <http://www.smac.fr/>
- [2] Flannelly, W. G, Application of Dynamic Antiresonant Vibration Isolator to Helicopter Vibration Control, US Naval Research Lab., Shock and Vibration Bulletin, Vol. 37, 95, Jan 1978, 63-81.
- [3] Rita, A. D., Helicopter Rotor Isolation Evaluation Using the Dynamic Antiresonant Vibration Isolator, J. of the American Helicopter Soc., Vol. 23, No.1, Jan 1978, 22-29.
- [4] L. Lecce, E. Monaco, Franco, Mesema (magneto-elastic energy system for even more electric aircraft): Objectives and first results, Proc. Actuator Conf, , Ed Messe Bremen, 2006, pp. 936–939.
- [5] Harris, C., Shock and Vibration Handbook (vol. 1), Mc Graw-Hill, New York.,1961
- [6] C. May, P. Optimisation of a magnetostrictive auxiliary mass damper, Proc. Actuator Conf, , Ed Messe Bremen, 2006, 2006, pp. 344–348.
- [7] R Leletty, New amplified piezoelectric actuator for precision positioning and active damping, Smart Structures and Mat. 1997 SPIE Vo.3041, p. 496-504
- [8] <http://www.cedrat-groupe.com/en/mechatronic-products/actuators/apa.html>
- [9] F. Claeysen, Magnetostrictive actuators compared to piezoelectric actuators, Eu.workshop on Smart Structures in Engineering and Technology, Ed. B. Culshaw, SPIE Vol. 4763, 2003, pp. 194-200
- [10] F.Claeyssen, Giant dynamic magnetostrain in rare earth-iron magnetostrictive materials, IEEE Trans. MAG.27, N°6, Nov.1991, pp 5343-5345.