

## DESIGN AND FUNCTIONAL TESTS OF A XY PIEZOELECTRIC STAGE FOR ROSETTA/MIDAS

F. Barillot<sup>(1)</sup>, R. Le Letty<sup>(1)</sup>, F. Claeysen<sup>(1)</sup>, N. Lhermet<sup>(1)</sup>, M. Yorck<sup>(2)</sup>

<sup>(1)</sup>Cedrat Recherche Comp., 10, Ch. De Pré Carré, ZIRST, F38246 MEYLAN Cedex, France, Phone +33(0)4.76.90.50.45., Fax +33(0)4.76.90.16.09. email : cedrat@cedrat.com

<sup>(2)</sup>SI IKOSS B.V., Haagse Shouwweg 8G, 2332 KG Leiden, The Netherlands.

### ABSTRACT

The ROSETTA/MIDAS space mission intends to analyze the dust resulting from the Wirtanen comet using an Atomic Force Microscope (AFM). To scan the dust, an extremely fine mechanism able to produce displacement's accuracy in the sub-micrometer range with a limited mass, is required. The only technology which can meet this specification is the piezoelectric actuator associated to capacitive displacement sensors, which displays several advantages : solid state design, which means no friction, noise limited by the driving electronic, ...

Under request of the European Space Agency (ESA), a XY stage able to produce a stroke of 100\*100  $\mu\text{m}$  has been developed by CEDRAT RECHERCHE. The required stroke is too high to be achieved directly by the active material. In addition, the mass budget for this mechanism is limited to 400gr. Therefore, the technology used in the Amplified Piezo Actuator (APA) currently produced by CEDRAT RECHERCHE has been preferred to other techniques such as mechanisms using hertzian pivots. The development includes also the guiding functions, especially needed to reduce the other parasitic degrees of freedom. An extensive Finite Element Analysis has been carried out.

The Engineering Model includes 8 APA50S actuators and two capacitive displacement sensors ; the functional performances are successfully tested, being closed to the predicted ones. The strokes and the parasitic degrees of freedom are measured using a laser interferometer. The stage has been tested over a temperature range from -20 to +50°C. A lifetime test (more than one million strokes) has been performed. The effects of these tests and other parameters such as piezoelectric drift effect, gravity, etc) on the functional performances are discussed.

A random vibration test at low level has also been performed for the purpose of comparison with the modeling. A latch mechanism for this stage based on Shape Memory Alloys actuators has been designed within a limited mass envelope.

This paper focuses on the design aspects, the tools used for this design and the lessons learned through this development.

### 1. INTRODUCTION

The ROSETTA / MIDAS mission intends to study the dust resulting from the Wirtanen comet using an Atomic Force Microscope (AFM) (Figure 1). This instrument utilizes a XY piezoelectric stage to achieve very fine displacements in two orthogonal directions and a Z actuator that support the needles for the analysis of dust particles. The piezoelectric actuators have been flown in several applications [1,2].

An AFM has never been flown and requires several degrees of freedom to be controlled in the mechanism :

- strokes of 100  $\mu\text{m}$  for scanning along both the X and Y directions, which cannot be attained with Direct Piezoelectric Actuators,
- stroke of 8  $\mu\text{m}$  along the Z direction,
- reduced (as small as possible) three parasitic rotations,
- only three independent electrical ports for X,Y and Z strokes can be used.

CEDRAT RECHERCHE designs and produces new piezoelectric actuators, called Amplified Piezoelectric Actuators (APA) [3,4]. The actuator does not include any weak part such as flexural hinges. The elastic amplifier can be used to directly prestress the Ceramic Multilayer Actuator (CMA) (in order to prevent ceramics from working in tensile stress), thus leading to an important mass saving. This stage has never been built nor experimented before. One difficulty is the need for a careful integration (especially for the capacitive sensors).Therefore, it was decided to use these actuators for the stage. The general concept is shown on the Figure 2 : the stage uses actuators in the X and Y directions to provide the required strokes and acts

also for the necessary guiding functions, by forming a parallelogram. Flexural hinges are used to decouple the X & Y axis, which remain identical for symmetry reasons. Z stiffeners are used to correct the parasitic rotations, induced along the X and Y strokes. Flexural hinges are preferred to hertzian pivots because the latter may lead to tribological problems.

The required angular deviations were also considered a serious difficulty, which cannot be handled independently of global design. The parasitic rotations appear in the project as an important point and it was requested to decrease the X and Y rotations down to 12  $\mu$ rad (which is a low value, not reached on commercially available products).

The design phase implies the use of the CAD softwares packages IDEAS-SDRC and ATILA to define the stage and verify the design by an extensive use of the Finite Element models. The prototype has therefore been built using numerical milling and electro - discharging machining. In a second step, the functional performances have been measured in the CEDRAT's laboratory. The thermal and lifetime tests were successful, but the stage was not able to pass the vibration levels imposed by the project requirements.

In a third step, the implementation of a latch mechanism has been studied. Due to the limited mass budget, only a few small latch actuators are available. A solution based on Shape Memory Alloy (SMA) actuators has been found compatible with the requirements and the available volume and mass budget, provided that mass savings are performed on the payload, which further leads to redesign a lightweight piezoelectric Z actuator.

## 2. DESIGN OF THE XY STAGE

To design the stage, both the ATILA and IDEAS-SDRC software packages have been used extensively combined with theoretical calculations. In its standard version, ATILA is a Finite Element Method software dedicated to the modeling of 2D/3D structures including active materials, while IDEAS-SDRC is used for a more standard mechanical analysis. The stage with its load has been modeled with ATILA for the definition of the stage shape and dimensions [5]. The static analysis provides the stroke and capacitance ; the modal analysis provides the vibration modes (frequencies and mode shape), their effective electromechanical coupling factors, the stress levels associated with the amplitudes of vibration. From these results the electromechanical properties of the stage may be defined and results such as the stiffnesses or the

resistance to launching vibrations may be deducted assuming the mode quality factor.

When designing mechanisms based on piezoelectric actuators, a great attention must be paid on the guiding functions. A  $k_t$  coefficient can be defined as :

$$k_t = \frac{k_a}{k_a + k_g},$$

where  $k_a$  is the actuator's stiffness,  $k_g$  is the guiding stiffness. The actuator's stroke is reduced in proportion of the  $k_t$  coefficient due to the guiding, which stores uncoupled elastic energy.

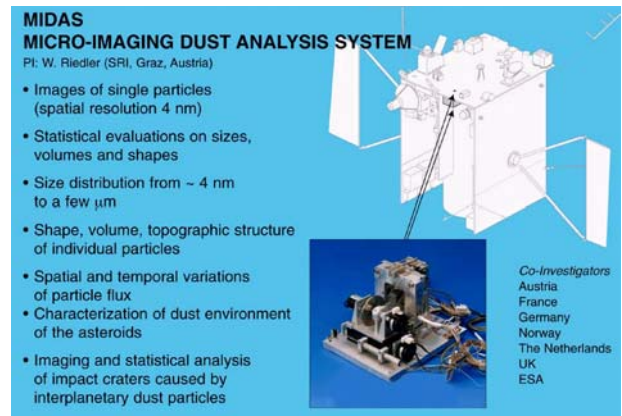

Figure 1 : Rosetta / Midas space mission (courtesy of ESA)

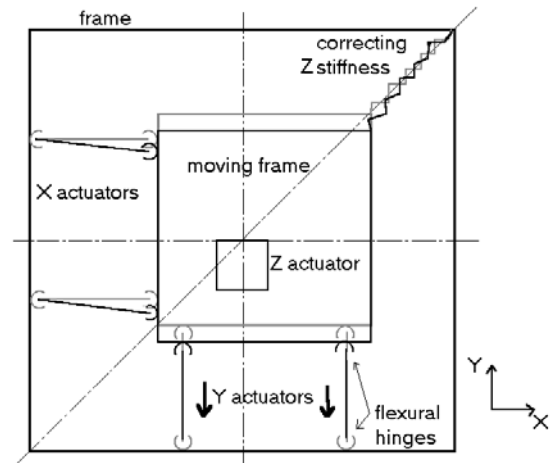

Figure 2 : Basic principle of the XY stage

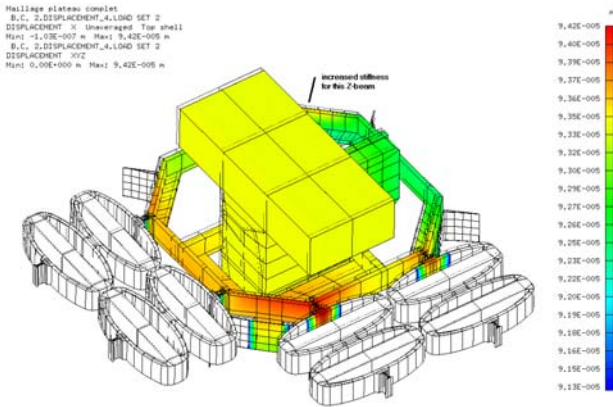

Figure 3 : ATILA FEM result : static excitation of the X actuators under 200 V.

### 3. FUNCTIONAL PERFORMANCES

A first prototype of the stage has been built : both the frame and the moving frame were made from stainless steel and machined through Electro Discharging Machining and Numerical Milling (Figure 4, Figure 5).

The XY stage is excited using SA75 drivers from CEDRAT RECHERCHE [4] and the functional performances are measured according the synoptic described on the Figure 6 :

- the X Y strokes,
- the open loop responses obtained from the capacitive displacement sensors (hysteresis measurement),
- the cross coupling between the axes (capacitive displacement sensors),
- the X Y Z deviations (measured using the laser interferometer).

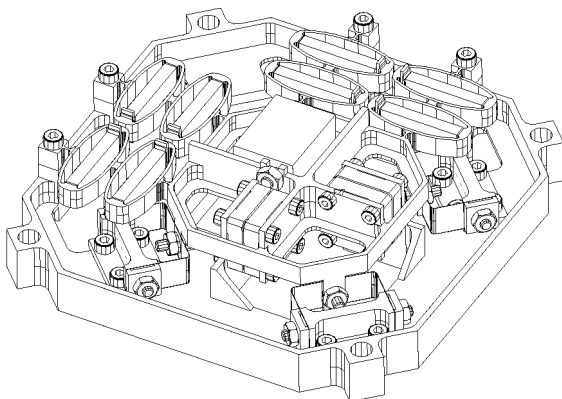

Figure 4 : Front view of the stage

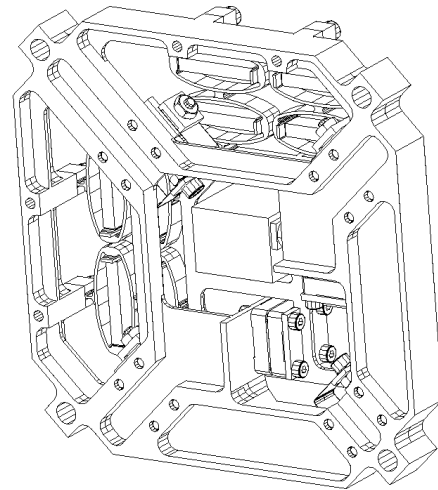

Figure 5 : Back view of the stage

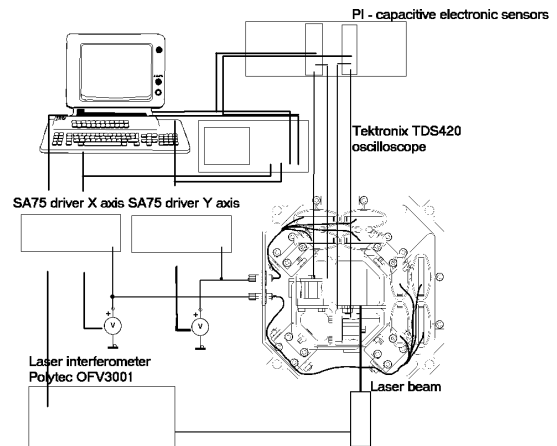

Figure 6 : Measurement principle of the stroke

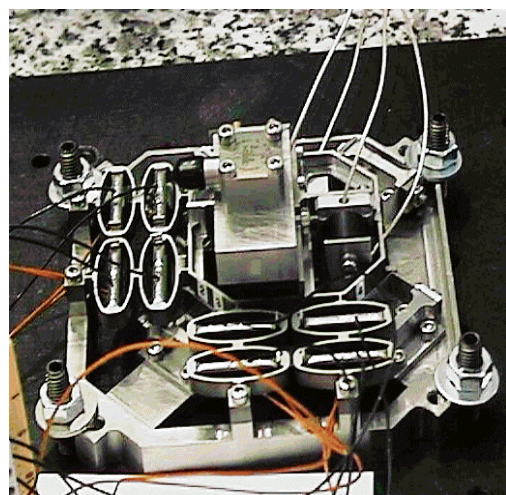

Figure 7 : View of the piezoelectric XY stage based on APA50S actuators and including the payload & a tri-axial accelerometer..

Both the stroke and the parasitic deviations have been measured.

The capacitive sensors and the laser interferometer responses are compared and found very similar. The linearity error is approximately less than 0.5 % and hidden in the noise's measurement (some sources of errors being the sampling resolution, the laser drift and parasitic ground vibrations).

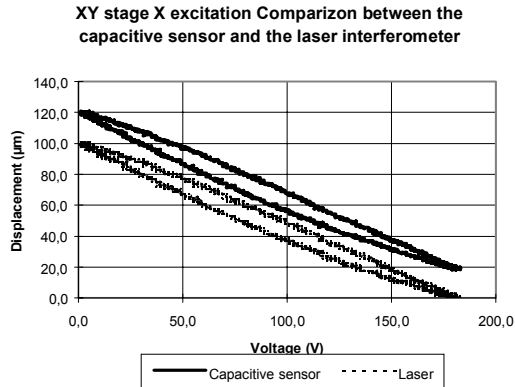

Figure 8 : Hysteresis measurement X axis excited (laser in position RX)(An offset is used for a clearer view)

Some remarks can be done :

- the discrepancies between the two axis of 1 % seem directly related to the behaviour's difference of the actuators,
- the strokes are found similar to those predicted (110 µm at room temperature),
- the ratio between the no-load actuators displacements and the stage displacements corresponds to the  $k_t$  coefficient, which is also the ratio between the actuators stiffness and the parallel stiffness, is comparable to the predicted values (0,88),
- the Z rotations (25 arcsec) are compliant with the specifications, but need to be optimized,
- the X and Y rotation, although not specified are comparable to the typical value of commercially available products,
- the cross - coupling between the X and Y axis measured on the sensors are less than 2 %.

## 4. THERMAL – VIBRATION - LIFETIME TESTS

### 4.1 Thermal test

The thermal range was  $-20 + 50^{\circ}\text{C}$ . The stroke at  $-10^{\circ}\text{C}$  is  $106 \mu\text{m}$ , while it is  $115 \mu\text{m}$  at  $40^{\circ}\text{C}$ . The total change of dimensions over the whole working temperatures range ( $50^{\circ}\text{C}$ ) is  $46.8 \mu\text{m}$ , which lead to a change of 4.68 V for the 0 sensors responses. This effect had to be taken into account both in the integration and in the design of the latch mechanism. Reducing the thermo - mechanical effects means reducing the thermo - mechanical mismatch between the CMA (Thermal Coefficient Expansion  $\alpha = 3.5^{\circ}\text{C}^{-1}/\text{K}$ ) and the shell's material ( $\alpha = 10.8^{\circ}\text{C}^{-1}/\text{K}$ ).

### 4.2 Vibration test

The stage was only submitted to the low level random vibrations (1g) for the purpose of comparison with the model predictions. Both the acceleration levels on the payload and the voltages appearing on the electrical ports were measured.

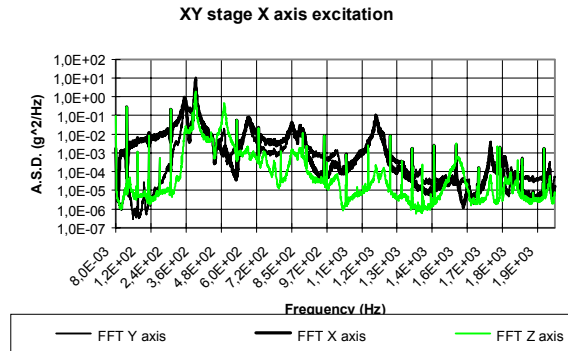

Figure 9 : A.S.D. level ( $\text{g}^2/\text{Hz}$ ) on the X axis excitation

The comparison is quite good in general. The vibrations modes are not equally damped and although elastomeric mounts have been used, some modes display a quality factor of 60. The translation and the rotation of the payload along the Z axis are more coupled than predicted for reasons that remain unclear (accelerometer's cable, ...).

### 4.3 Lifetime test

The stage did not show any significant changes during the tests ( $1.25^{\text{e6}}$  cycles). The variations are due to the room temperature, which was  $20 \pm 1^{\circ}\text{C}$ , and influence the 0 sensor response (see thermal test :  $0.9 \mu\text{m}/\text{K}$ ) and the gain of the driver SA75 (estimated to  $0.1 \%/ \text{K}$ ).

## 5. DESIGN OF THE LATCH MECHANISM

A design of a latch mechanism for the XY piezoelectric stage is proposed. A strong requirement was the absence of generated pollution. A trade-off between several technologies has been done [6]. The preferred solution is based on two Shape Memory Alloys actuators [7], arranged along the X & Y directions (Figure 10). The solution is compliant with the mass budget and the available volume and will not therefore interfere with the other mechanism of the instrument. This mass compliance was achieved thanks to a redesign of a lightweight Z actuator (in order to increase the first vibration mode) (Figure 12) ; its mass is less than 20 gr. It leads to a compact mechanism (Figure 11).

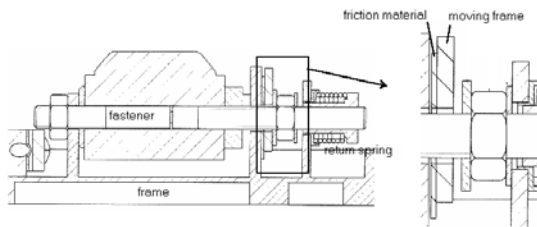

Figure 10 : Design of the latch mechanism

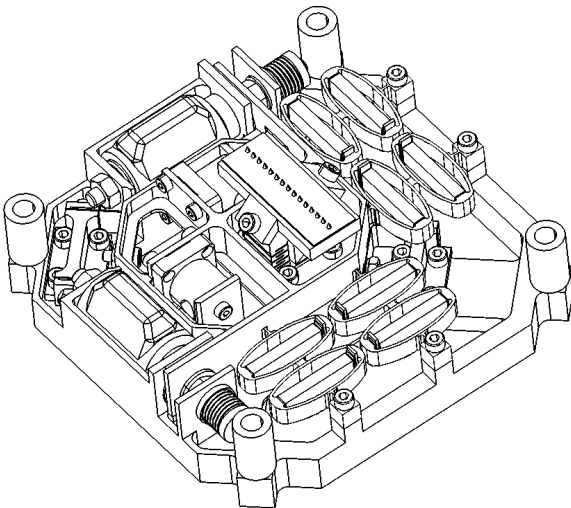

Figure 11 : View of the final stage including the latch mechanism in the locked configuration.

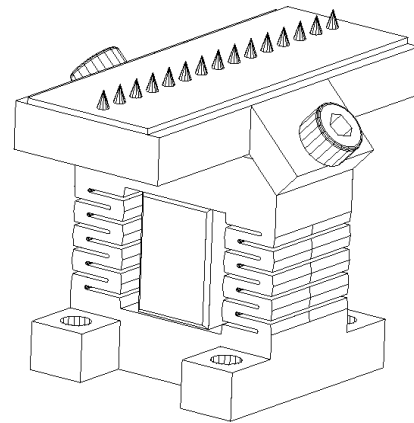

Figure 12 : Piezoelectric Z actuator supporting the needles.

The main points of the latch mechanisms are :

- although the latch joints are designed quite stiff, the thermo- mechanical and creep effect are small, so that a good margin of preload against vibration loads is obtained,
- a general novelty of the mechanism due to the used friction plans, because the conventional cup-cone configuration cannot be used due to small clearances,
- due to the small deformation angles, the non synchronism of the two latch actuators should not be a problem. It is however difficult to assess it from the theoretical point of view,
- the shock effects should be small because the elastic stored energy in the broken fastener is small.
- very low clearances in the unlocked configuration, which should be compatible with the thermo - mechanical behavior of the stage over the whole working temperature range,
- stringent requirements regarding the pollution and the debris generated by the fasteners breaks, for which no data is available : it could lead to confine the internal volume of the SMA actuator in a qualified/flight model,
- the force of the return spring should be higher than the possible adhesion force between the nut and the moving frame, after the fastener's break. In the absence of separation, the return spring behaves in parallel to the piezo actuator, thereby reducing its stroke.
- the nominal power of the SMA actuator is 25 W, while only 10 W are available. TiNi Aerospace insured that 10W will break the fastener, at the expense of a longer heating time. This lowers the efficiency by 40 %.

## 6. CONCLUSION : LESSONS LEARNED & PERSPECTIVES

The design of the stage cannot be separated from the piezoelectric actuator design and the capacitive sensors which imply very accurate distances between the two sensors parts. Further, it has also some strong consequences on the possible solutions for the implementation of a latch mechanism.

Due to both the small mass budget (and consequently limited stiffness) and the above mentioned distance, the stage is sensitive to several factors :

- fixation,
- gravity,
- temperature.

The required functional performances have been attained. Although the model predicted a solution to remove the Z angular deviation, the latter has been measured within the envelope of the requirement. Optimizing the shape of the Z beam can reduce this angular deviation.

The thermo-mechanical behavior is not optimized as the amplified piezo actuator APA50S itself has an expansion of  $-0.5 \mu\text{m/K}$ , due to the thermo - mechanical mismatch between the CMA and the steel of the shell.

By sorting the CMAs, comparable strokes between them can be obtained. High quality factors have been measured : there is a need for damping materials, preferably included in the guiding system, so as to avoid additional errors of the guiding function by adding the elastomeric mounts.

The functional and the modal behaviors have been quite well estimated by the Finite Element Models :

- the modes are predicted with an error below 5%,
- the strokes were closed to prediction before improvements, which comes from the contact stiffness inside the actuator (the model of the actuator can be further re-updated),
- parasitic displacements are quite well reproduced (X-Y rotation for instance)
- the clamping of the Z-beams stiffeners are overestimated by the model,
- the thermo - mechanical model is quite well representative.

As a conclusion, this mechanism, based on piezoelectric actuators, is a 6 degrees of freedom in nature, because 3 of them must be actively controlled and the three others must be passively canceled.

Specificities are low allowed mass budget, high strokes that cannot be attained through Direct Piezoelectric Actuators use.

The extensive use of finite element models, which have been proved close to the measurement helped the design : the functional performances were obtained on the first prototype. To obtain minimized parasitic rotations, a high quality of symmetry in the mechanism is necessary, thereby leading to sort the Ceramic Multilayer Actuators as an example. Thermal and lifetime tests did not degrade the functional properties beyond the requirements. Therefore, the technology can be considered mature for this new space mission.

## 7. ACKNOWLEDGEMENTS

This work has been performed under ESA TRP contract n°13090/98/NL/MV. The European Space Agency is gratefully acknowledged.

## 8. REFERENCES

- [1] Fanson J.L., 1995, On the use of electrostrictive actuators in recovering the optical performance of the Hubble space telescope, Mat. Res. Soc. Symp. Proc., 360, 109-120.
- [2] Burger F., Eder J., 1995, High precision pointing device for the LASCO instrument on SOHO, 6<sup>th</sup> ESMATS Proc., 9-14.
- [3] Le Letty R., Claeysen F., Thomin G., 1997, A new amplified piezoelectric actuator for precise positioning and semi-passive damping, 2<sup>nd</sup> Space Microdynamics & Accurate Control Symp., 389-401.
- [4] Cedrat Piezo Products catalogue, 1999 version, Ed. Cedrat (Meylan, F), 50 p.
- [5] ATILA : FEM software for Smart Materials and Structures, developed by ISEN (F) and distributed by Cedrat (Europe) & Magsoft (USA).
- [6] Lucy M., Hardy R., Kist E., Watson J., Wise S., 1994, Report on alternative devices to pyrotechnics on spacecraft, NASA Langley Res. Center report.
- [7] Frangibolt ® actuator, TiNi Aerospace.